

IGS 读头尺寸规格表

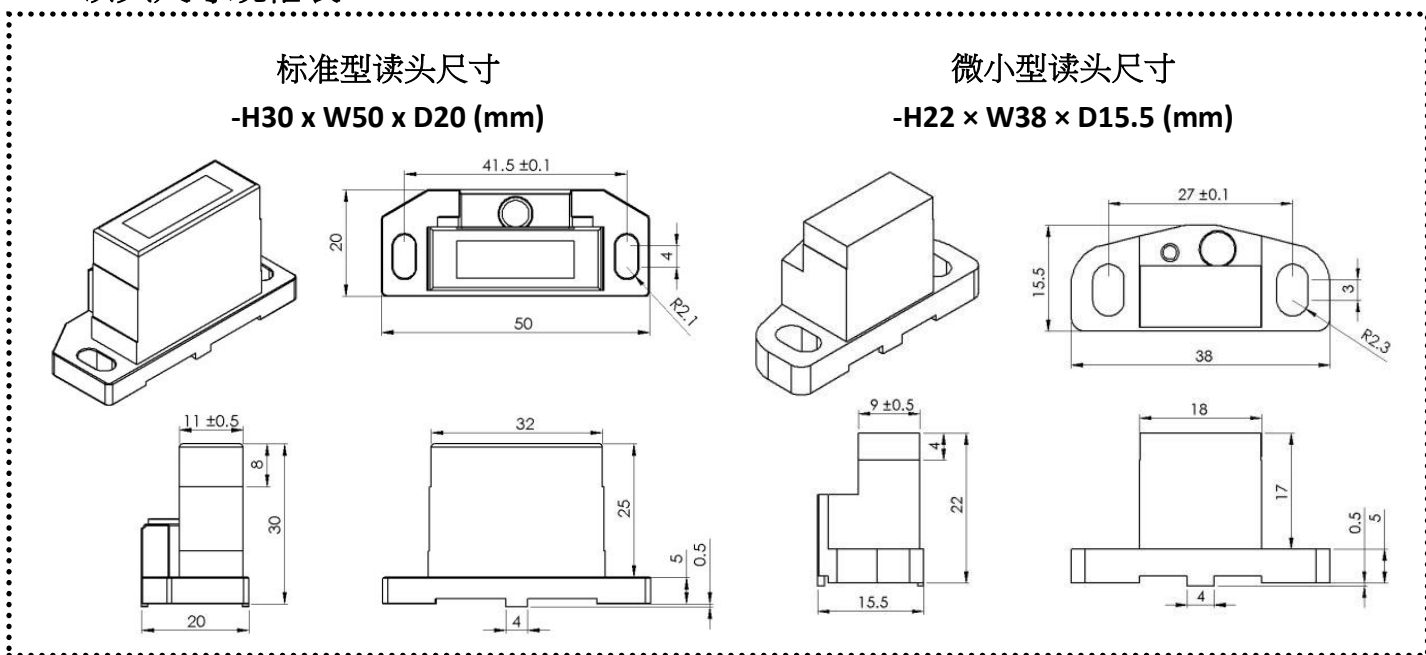

IGS 安装配置图

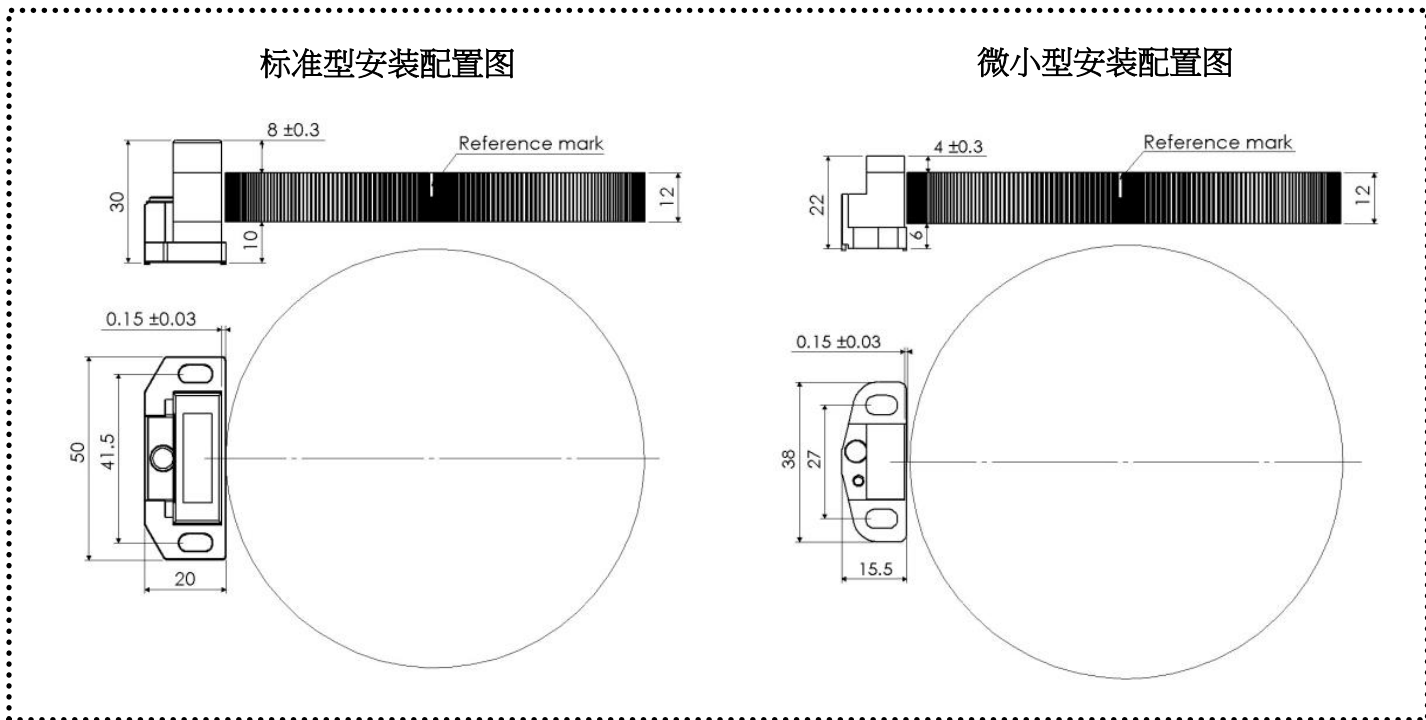

标准齿轮规格

Type	DX (mm)	ld (mm)	Dh (mm)	Ha (mm)	teeth
GR 04-512.A01	205.6	180	194.4	4.5	512
GR 04-384.A01	154.4	108	120	4.5	384
GR 04-256.A01	103.2	82	92	4.5	256
GR 05-256.A01	129	95	112	4.5	256
GR 04-128.A01	52	35	43	3.5	128
GR 05-128.A01	65	50	57	3.5	128
GR 04-128.A02	52	30	41	3.5	128
GR 05-128.A02	65	40	53	4.2	128